

setra^{lite}™

Quick Mount Kit

Features

- Simple single-room pressure indication for all pressurized healthcare spaces - works for both permanent and temporary spaces
- Simple to install. Mount with a single hook
- Visual alarm via red/green light ring
- Silent operation, no audible alarm
- Saves preventive maintenance from manually checking each room
- Offset light pipe that can be seen at an angle or down a hallway
- Digital display can be always-on or momentary
- Full configuration is easy, using just 3 buttons
- Analog output provides pressure reading to BMS system

Accurate measuring & display

Setra Lite provides a simple, cost-effective, and accurate way to measure and display room differential pressure in areas today that require manual verification. For local staff managing an area, Setra Lite has a light ring that is green or red, showing a clear indication of room conditions. For the facility manager, using Setra Lite means the frequency of preventative maintenance walk-by inspections can be reduced because Setra Lite is monitoring the space.

Setra Lite features

Setra Lite has many features found only in larger, more complex room pressure monitors. These include a bright light ring that can be seen at an angle or down a hallway, a digital display of the pressure value that is always-on or momentary, an alarm delay for door entry, and POS or NEG room mode. The Setra Lite sensor has Setra's accuracy and reliability you know you can trust.

Simple installation

Setra Lite is about the size of a standard light switch, and just as a simple to install. It fits in a single-gang US electrical box, international 86-box or international round back-box, and is powered by 24VAC or 24VDC. The Quick Mount Kit allows for mounting with a single hook. The Quick Mount Kit also comes with an AC power adapter that can be plugged into a generator or a 9V battery pack for situations where wiring may not be available.

Applications

Ideal solution for emergency installations, including:

- Emergency ICU tents
- Mobile Field Hospitals
- Recently re-configured rooms



Pressure indication



Simple green status



Red indicates alarm



Specifications

Physical description

Dimensions	4"W x 7.5"L x 2.5" Deep
Mounting	Temporary mounting plate with single clearance hole
Case	Fire-retardant plastic UL94 V-0 and Aluminum bracket
Weight	11 oz (0.7 lbs)
Display	Color: RGB, 65K Resolution: 128x160, backlight: LED
Alarm indication	Red illuminated LED light ring, 11mm standoff from faceplate, viewable at 90° angle from side

Performance

Accuracy ¹	±0.5% FS
Non-linearity (BFSL)	±0.44% FS
Hysteresis	±0.10% FS
Non-repeatability	0.05% FS
Span Tolerance	±1% Rdg
Thermal effects ²	
Zero shift %FS/°F (°C)	±0.033 (±0.06)
Span shift %FS/°F (°C)	±0.033 (±0.06)
Long-term stability	±0.5% FS per year
Overpressure	±1 PSI (15" WC for <0.10" WC FS)
Pressure media	Air or non-conductive, non-explosive gases
Pressure fittings	3/16" barbed fitting
Position	Mount vertically

Environmental data

Operating temp. °F (°C)	32 to 120 (0 to 50)
Storage temp. °F (°C)	-20 to 160 (-30 to 70)
Operating humidity	5 to 95% RH (non-condensing)
Ingress protection (IP) rating	IP54

¹ RSS of non-linearity, non-repeatability, and hysteresis

² Units calibrated at nominal 70°F maximum thermal error computed from this datum

³ Zero tolerance negated by zero push button

Display

Light ring	Green, red, or off
Numeric value	4 digits

Features

Re-zero	Single press-and-hold to re-zero sensor
Alarm thresholds	Set numeric threshold in "WC or Pa
Door delay	Set door alarm delay for 0-999 seconds
POS or NEG indicator	Set display to show POS, NEG, or off
Display on/off	Set display to always-on, or momentary press to show pressure value
Significant digits	1,2, or 3 after decimal point, POS or NEG
Light ring	Set LED ring to 1). steady green, steady red if alarm, 2). Green OFF, and steady red if alarm 3). always of
Units	Set units on the display to show "WC or Pa

Electrical

Power	24 VAC (+/-10%) 24VDC (18-32) 50-60 HZ 9V battery pack and AC adapter included
Power draw	2W max, 1W typical
Analog output ³	Set for 0-5V, 0-10V, or 4-20mA signal
Wire	Stranded unshielded twisted-pair, 18-24 AWG
Terminals	Fixed, non-removable

Regulatory compliance

CE, RoHS

Ordering information

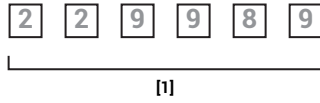

[1]	
Model	
229989	Temporary Mounting Kit

Includes

- LITER25WBD (+/- 0.25" WC Unit)
- Battery Pack
- AC Adapter with 6-foot cord
- RPS Single Gang Filtered Pressure Port
- Mounting bracket

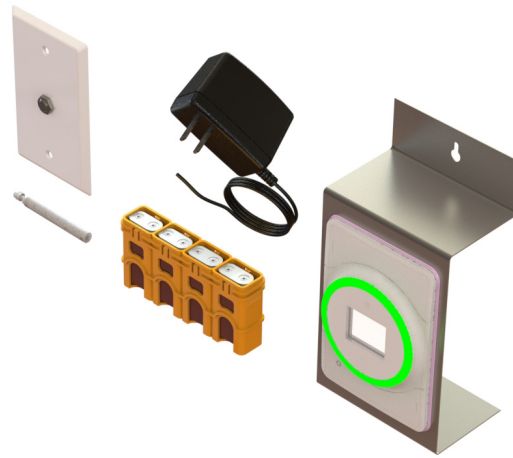

Dimensions

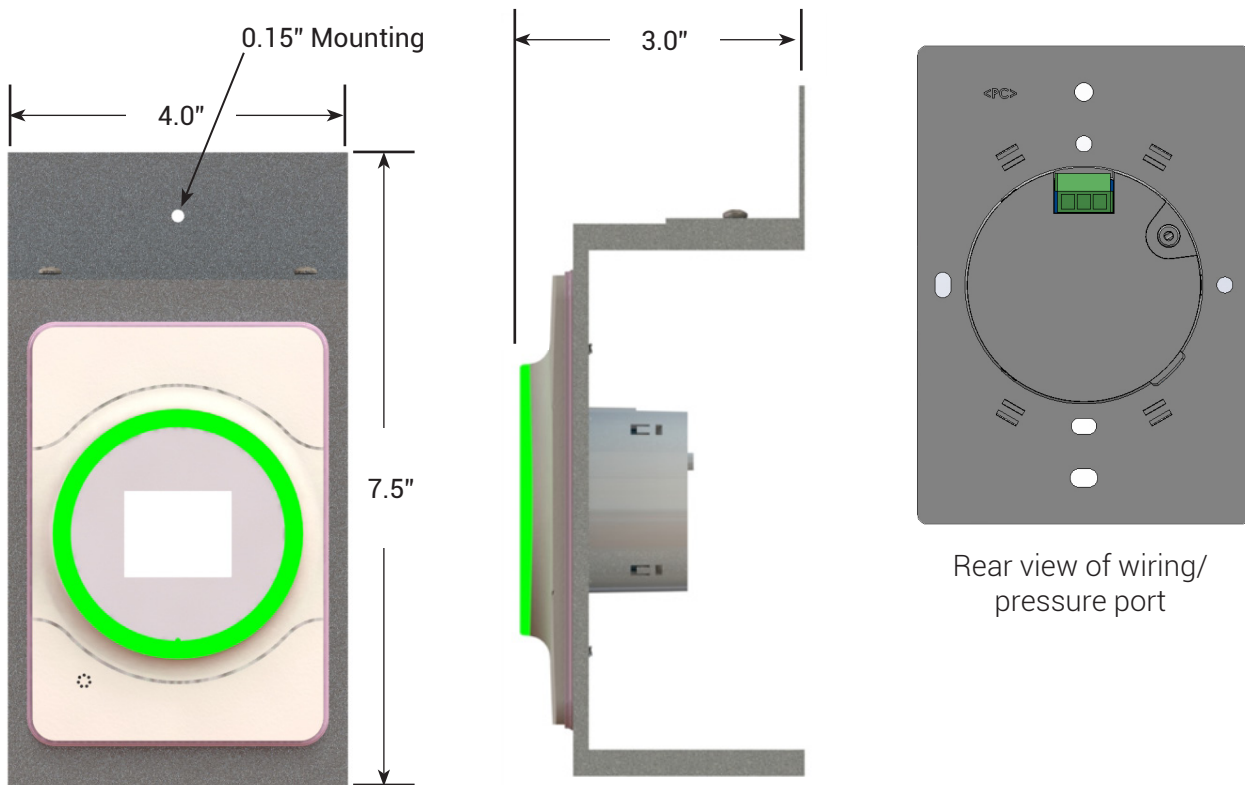

Rear view of wiring/
pressure port



Setra Systems, Inc.
159 Swanson Road
Boxborough, MA 01719
800.257.3872
www.setra.com

© Setra Systems, Inc. All rights reserved.

The Setra Systems name and logo
are trademarks of Setra Systems, Inc.