

setra

OPERATING INSTRUCTIONS MODEL 141 ACCELEROMETER

GENERAL INFORMATION

Your Setra accelerometer has been carefully calibrated before shipment to you, and it should be handled with the same care given any precision instrument. Setra accelerometers are rugged devices, built to take considerable overrange of "G" loads.

Please refer to the Model 141 calibration data before proceeding further.

ELECTRICAL CONNECTIONS

Cable Lead	Function
White	positive excitation
Black	negative excitation
Yellow	positive output
Brown	negative output
Red	calibration signal
Shield	case

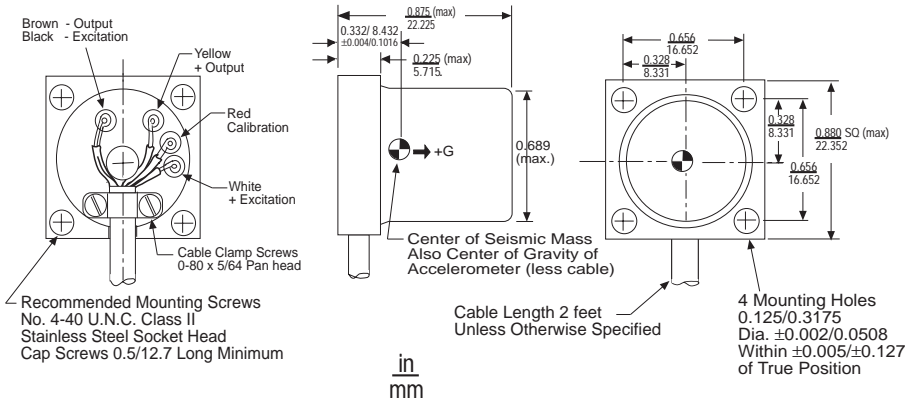

CAUTION: BE ABSOLUTELY SURE OF EXCITATION POWER POLARITY BEFORE APPLYING POWER, REVERSED EXCITATION WILL BURN OUT THE CIRCUIT INSTANTLY.

MODEL 141A MUST NOT BE OPERATED WITH EXCITATION EXCEEDING 15 VDC.

Model 141A accelerometer excitation voltage 5 VDC to 15 VDC. Keep excitation power between 5 VDC min. and 15 VDC maximum. High voltage may burn out the circuit. Installation of a protective Zener diode such as a 1N4746A across the excitation power input leads is a good practice, taking care to

orient the diode correctly. This Zener diode protects the transducer circuit against high voltage transients and against inadvertent application of excess voltages or reversed voltage. Note that the Zener diode normally conducts up to 200 milliamperes satisfactorily but that excessive current drain will cause the Zener diode to short-circuit internally, hopefully protecting the transducer from damage. Should this happen, the Zener diode must of course be replaced before further use of the transducer.

MODEL 141B MUST NOT BE OPERATED WITH EXCITATION VOLTAGE EXCEEDING 28 VDC

Model 141B accelerometer excitation power 10 VDC minimum and 28 VDC maximum. High voltage may burn out the circuit. Installation of a protective Zener diode such as IN4752 across the excitation power input leads is a good practice, taking care to orient the diode correctly. This Zener diode protects the transducer circuit against high voltage transients and against inadvertent application of excess voltages or reversed voltage. Note that the Zener diode normally conducts up to 30 milliamperes satisfactorily but that excessive current drain will cause the Zener diode to short-circuit internally, hopefully protecting the transducer from damage. Should this happen, the Zener diode must of course be replaced before further use of the transducer.

CALIBRATION SIGNAL

Select an external R_{CAL} and shunt the red lead through R_{CAL} to the brown lead (-signal output). An R_{CAL} value is shown on the calibration certificate. Less conductive resistors produce a nearly proportional decrease in calibration signal. Higher conductivity resistors produce a similarly proportional increase in calibration signal.

THE CALIBRATED OUTPUT OF YOUR ACCELEROMETER

Your accelerometer was factory-calibrated on a centrifuge at a precise excitation voltage reported on the calibration certificate. The accelerometer output voltage was measured into open circuit (10 megohms). The output impedance of the 141 accelerometer is 9K ohms (nominal). Loading effect on the output does not appreciably change the linearity or thermal behavior of the transducer. The output into heavy loads may be calculated by assuming simple voltage divider action. The sensitivity is approximately proportional to the excitation voltage.

RETURNING PRODUCTS FOR REPAIR

Please contact Setra (1-800-257-3872, 978-263-1400) before returning unit for repair to review information relative to your application. Many times, only minor field adjustments may be necessary. When returning a product to Setra, the material should be carefully packaged and shipped prepaid to:

Setra Systems, Inc.
159 Swanson Road
Boxborough, MA 01719
Attn: Repair Department

To assure prompt handling, please supply the following information and include it inside the package of returned material:

1. Name and phone number of person to contact.
2. Shipping and billing instruction.
3. Full description of the malfunction.
4. Identify any hazardous material used with product.

Notes: Please remove any pressure fittings and plumbing that you have installed and enclose any required mating electrical connectors and wiring diagrams.

Allow approximately 3 weeks after receipt at Setra for the repair and return of the unit.

Non-warranty repairs will not be made without customer approval and a purchase order to cover the repair charges.

Calibration Services

Setra maintains a complete calibration facility that is traceable to the National Institute of Standards & Technology (NIST). If you would like to recalibrate or recertify your Setra pressure transducers or transmitters, please call our Sales Department at 1-800-257-3872 (978-263-1400) for scheduling, cost and turnaround estimates.

Thank you,
Setra Systems, Inc.

LIMITED WARRANTY AND LIMITATION OF LIABILITY

SETRA warrants its products to be free from defects in materials and workmanship, subject to the following terms and conditions: Without charge, SETRA will repair or replace products found to be defective in materials or workmanship within the warranty period; provided that:

- a) the product has not been subjected to abuse, neglect, accident, incorrect wiring not our own, improper installation or servicing, or use in violation of instructions furnished by SETRA;
- b) the product has not been repaired or altered by anyone except SETRA or its authorized service agencies;
- c) the serial number or date code has not been removed, defaced, or otherwise changed; and
- d) examination discloses, in the judgment of SETRA, the defect in materials or workmanship developed under normal installation, use and service;
- e) SETRA is notified in advance of and the product is returned to SETRA transportation prepaid.

Unless otherwise specified in a manual or warranty card, or agreed to in a writing signed by a SETRA officer, SETRA pressure and acceleration products shall be warranted for one year from date of sale.

The foregoing warranty is in lieu of all warranties, express, implied or statutory, including but not limited to, any implied warranty of merchantability for a particular purpose.

SETRA's liability for breach of warranty is limited to repair or replacement, or if the goods cannot be repaired or replaced, to a refund of the purchase price. SETRA's liability for all other breaches is limited to a refund of the purchase price. In no instance shall SETRA be liable for incidental or consequential damages arising from a breach of warranty, or from the use or installation of its products.

No representative or person is authorized to give any warranty other than as set out above or to assume for SETRA any other liability in connection with the sale of its products.