



INSTALLATION INSTRUCTIONS MODEL 892 ELECTRICAL ENCLOSURE FOR

265 SERIES PRESSURE TRANSDUCERS AND TRANSMITTERS

The Model 892 electrical enclosure kit includes the following:

- Transducer/transmitter mounting bracket
- Plastic Conduit Cover
- Block of pressure range labels
- Installation instructions
- Two (2) Mounting Screws

INSTALLATION

1. Mount the 892 mounting bracket to any solid surface, in any orientation, using standard available hardware, #6 screw recommended. Avoid locating directly on high vibration equipment such as air handling units.
2. Mount the 265 pressure transducer or transmitter to the 892 bracket with the 2 mounting screws provided. Orient terminal strip of the transducer/transmitter to opening in mounting bracket.
3. Install conduit and wire per the 265 operation instructions.
4. Snap the plastic cover into place over the bracket.

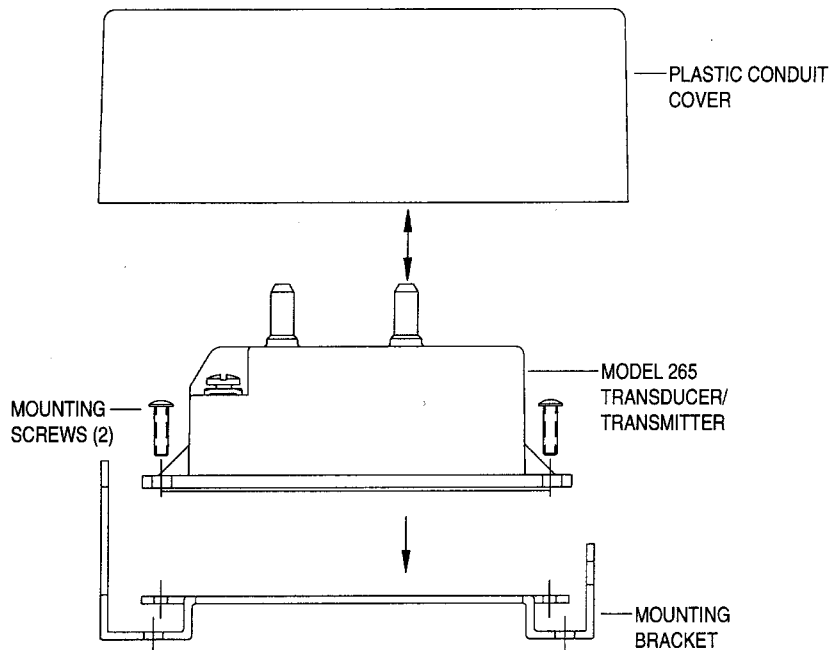

RETURNING PRODUCTS FOR REPAIR

Please contact Setra (1-800-257-3872 or 978-263-1400) before returning unit for repair to review information relative to your application. Many times, only minor field adjustments may be necessary. When returning a product to Setra, the material should be carefully packaged and shipped prepaid to:

Setra Systems, Inc.
159 Swanson Road
Boxborough, MA 01719-1304
Attn: Repair Department

To assure prompt handling, please supply the following information and include it inside the package of returned material:

1. Name and phone number of person to contact.
2. Shipping and billing instructions.
3. Full description of the malfunction.
4. Identify any hazardous material used with product.

Notes: Please remove any pressure fittings and plumbing that you have installed and enclose any required mating electrical connectors and wiring diagrams.

Allow approximately 3 weeks after receipt at Setra for the repair and return of the unit.

Non-warranty repairs will not be made without customer approval and a purchase order to cover repair charges.

159 Swanson Road, Boxborough, MA 01719-1304; 800-257-3872;
(978) 263-1400; Fax. 978-264-0292; WEB; www.setra.com;
E-mail: transducer.sales@setra.com



SSO549Rev. A 07/31/98